

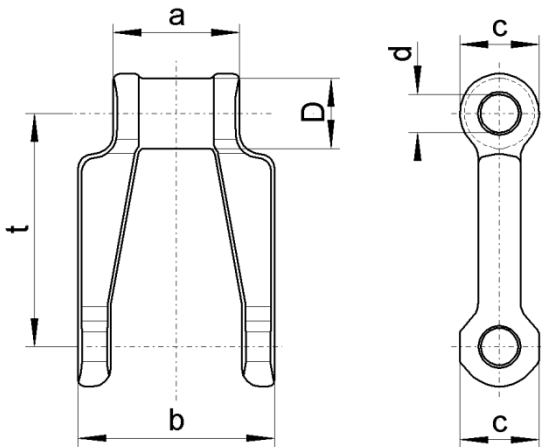

HEAVY DUTY DRIVE CHAIN

- drop-forged and hardened
- extremely strong and resilient
- large joint surfaces = reduced wear = low elongation
- weldable

Rübig - Heavy Duty Chains are made from boron alloyed, forged steel. Entrainment bars, cross-bars, etc. can be welded directly onto the chain links. An inexpensive alternative are extended chain pins as a fixation.



dimensions in [mm]						
size	pitch t	a	b	c	d	D
50	50	27	42	17	8	15
100 xs	100	27	42	17	8	15
100 s	100	45	72	28	12	24